



1028 Opelika Road,
 Auburn, AL 36830
 Ph: (334) 826-9538
 Fax: (334) 826-9539

AAON

RM-A000-SB-073-14,18,24,36
 A Box (2 - 7 Ton)

Customer: _____ Project: _____
 Ship To: _____ PO Number: _____

 _____ Approved By: _____

Standard Features:

- Welded SB 18ga G90 galvanized steel construction
- 14, 18, 24 or 36 inches high
- Factory installed PT 1x4 wood nailer
- Supplied 1-1/2x1/4" closed cell neoprene gasket
- 1"x1.5# insulation

Options (please check):

- Heavier gauge metal
- 5052-H32 AL or 304 SS construction
- Custom height
- Slope
- Horizontal duct connections
- Turning vane
- 1" or 2" isolation rails
- Seismic rating/stamped
- Filtration
- Metal Building construction
- Other per customer specs

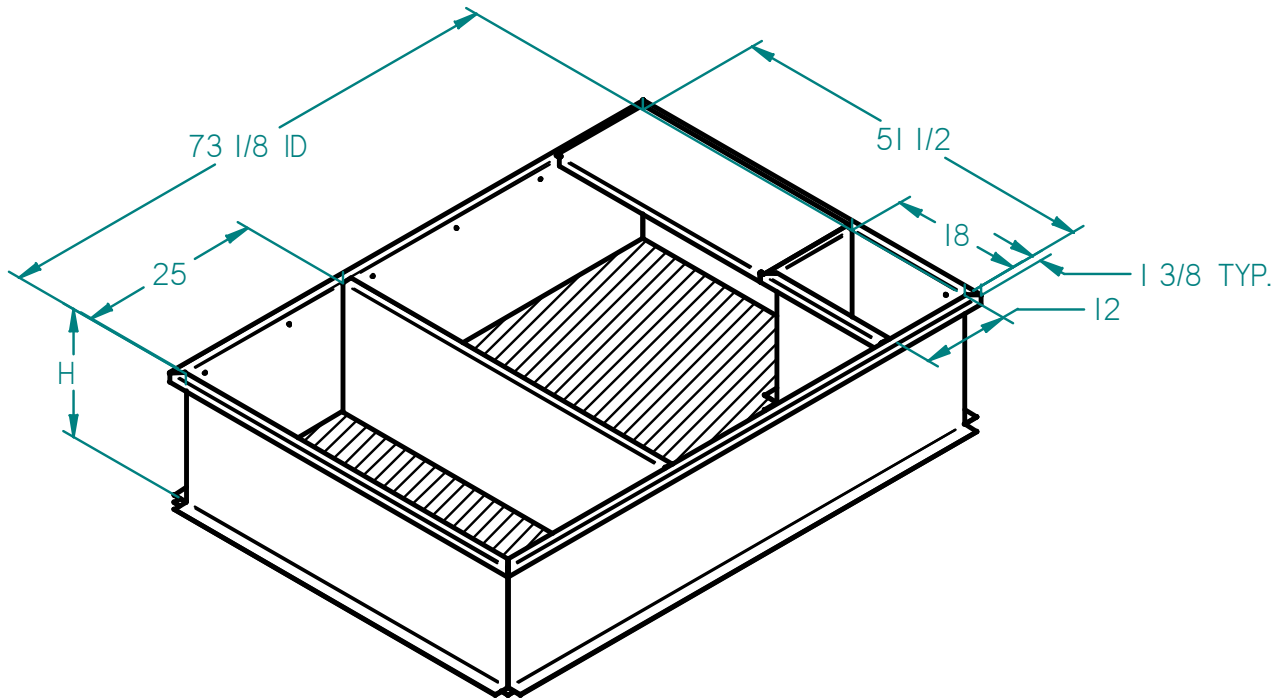

QUANTITY	HEIGHT	OPTIONS	SPECIAL NOTES



1028 Opelika Road,
 Auburn, AL 36830
 Ph: (334) 826-9538
 Fax: (334) 826-9539

AAON

RM-A000-SB-113-14,18,24,36
 A Box (2 - 7 Ton) w/ Heat Wheel

Customer: _____ Project: _____
 Ship To: _____ PO Number: _____

 _____ Approved By: _____

Standard Features:

- Welded SB 18ga G90 galvanized steel construction
- 14, 18, 24 or 36 inches high
- Factory installed PT 1x4 wood nailer
- Supplied 1-1/2x1/4" closed cell neoprene gasket
- 1"x1.5# insulation

Options (please check):

- Heavier gauge metal
- 5052-H32 AL or 304 SS construction
- Custom height
- Slope
- Horizontal duct connections
- Turning vane
- 1" or 2" isolation rails
- Seismic rating/stamped
- Filtration
- Metal Building construction
- Other per customer specs

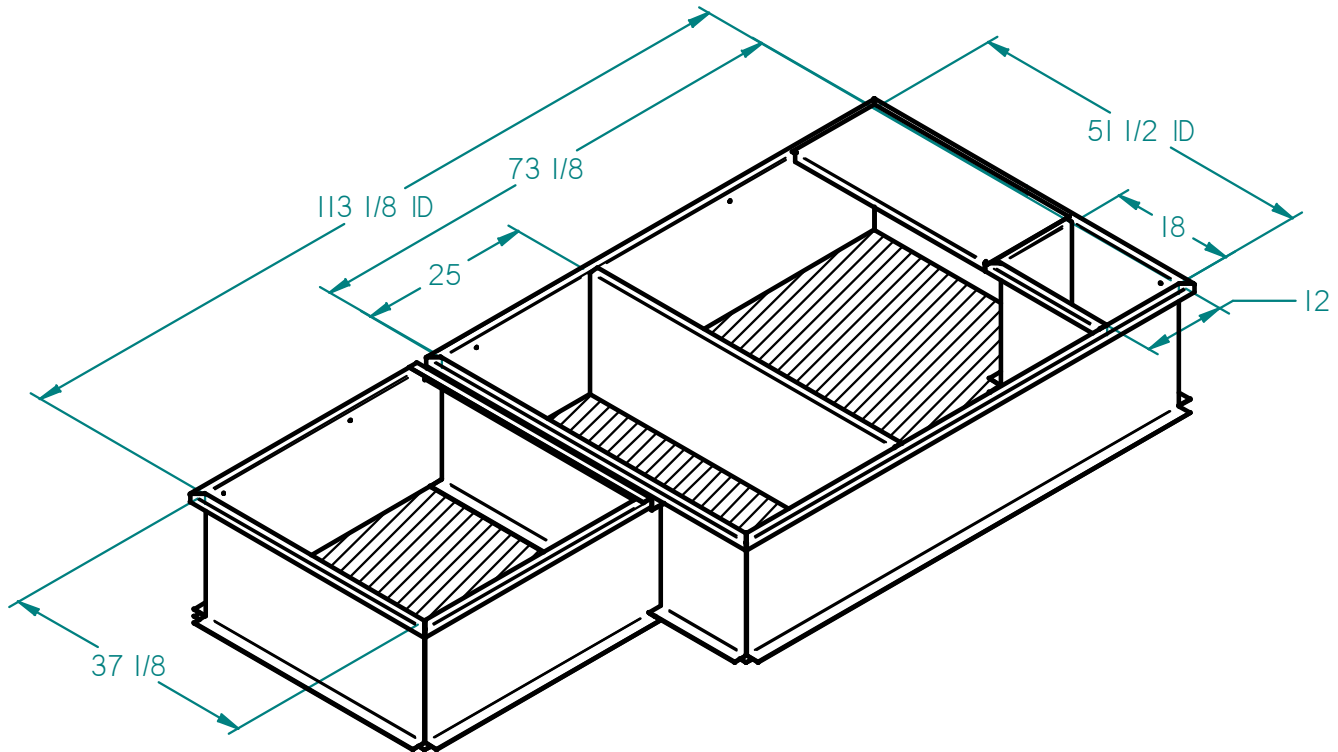

QUANTITY	HEIGHT	OPTIONS	SPECIAL NOTES



1028 Opelika Road,
Auburn, AL 36830
Ph: (334) 826-9538
Fax: (334) 826-9539

AAON

RM-A000-KD/FW-073-14,18,24,36-DR
A Box (2 - 7 Ton) w/ Duct Rails

Customer: _____ Project: _____
 Ship To: _____ PO Number: _____

 _____ Approved By: _____

Standard Features:

- Knock Down or Welded 18ga G90 galvanized steel construction
- 14, 18, 24 or 36 inches high
- Factory installed PT 1x4 wood nailer
- Supplied 1-1/2x1/4" closed cell neoprene gasket
- 1"x1.5# insulation

Options (please check):

- Heavier gauge metal
- 5052-H32 AL or 304 SS construction
- Custom height
- Slope
- Horizontal duct connections
- Turning vane
- 1" or 2" isolation rails
- Seismic rating/stamped
- Filtration
- Metal Building construction
- Other per customer specs

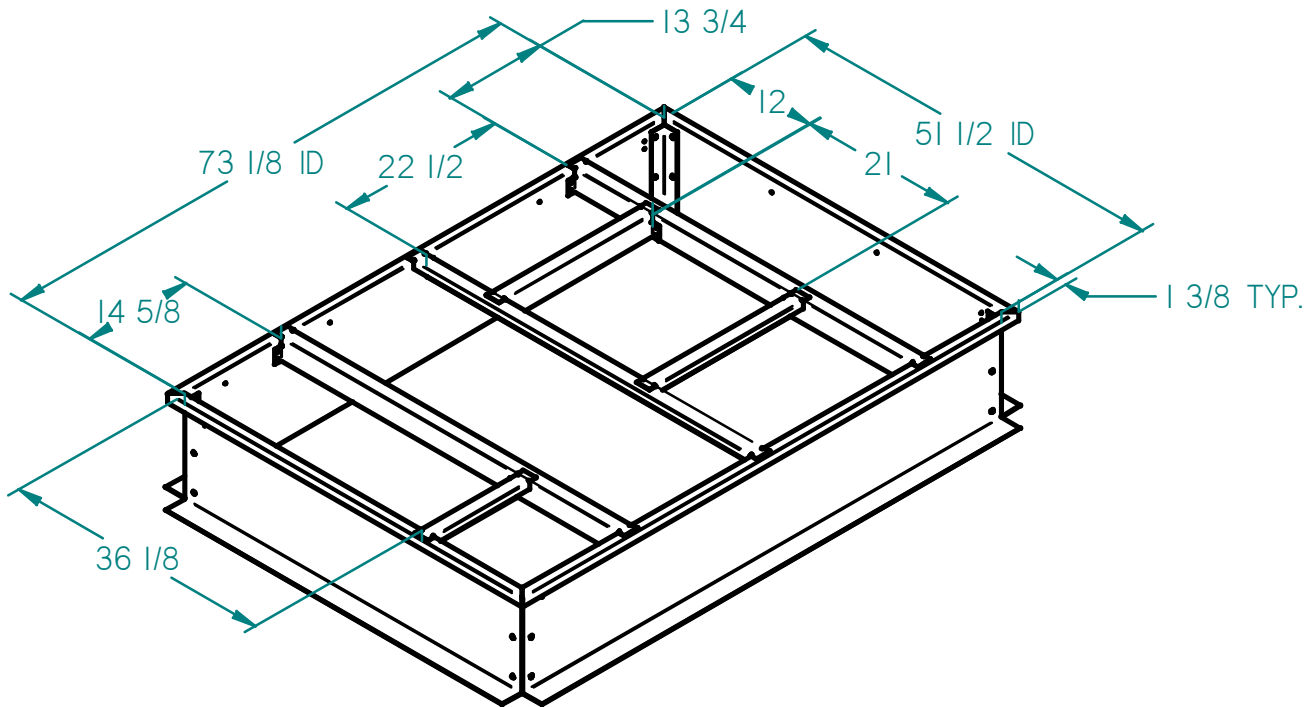

QUANTITY	KD / FW	HEIGHT	OPTIONS	SPECIAL NOTES



1028 Opelika Road,
 Auburn, AL 36830
 Ph: (334) 826-9538
 Fax: (334) 826-9539

AAON

RM-A000-KD/FW-113-14,18,24,36-DR

A Box (2 - 7 Ton) w/ Heat Wheel & Duct Rails

Customer: _____ Project: _____
 Ship To: _____ PO Number: _____

 _____ Approved By: _____

Standard Features:

- Knock Down or Welded 18ga G90 galvanized steel construction
- 14, 18, 24 or 36 inches high
- Factory installed PT 1x4 wood nailer
- Supplied 1-1/2x1/4" closed cell neoprene gasket
- 1"x1.5# insulation

Options (please check):

- Heavier gauge metal
- 5052-H32 AL or 304 SS construction
- Custom height
- Slope
- Horizontal duct connections
- Turning vane
- 1" or 2" isolation rails
- Seismic rating/stamped
- Filtration
- Metal Building construction
- Other per customer specs

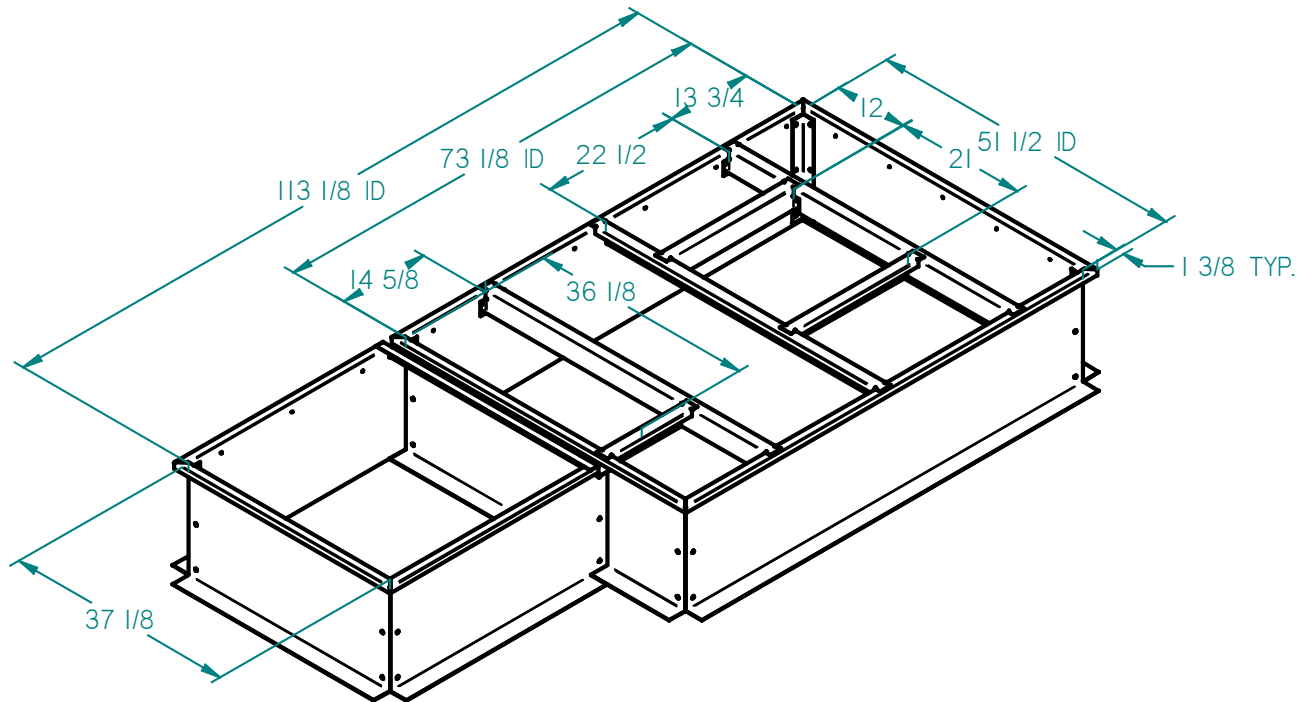

QUANTITY	KD / FW	HEIGHT	OPTIONS	SPECIAL NOTES



1028 Opelika Road,
 Auburn, AL 36830
 Ph: (334) 826-9538
 Fax: (334) 826-9539

AAON

RN-B000-SB-073-14,18,24,36
 B Box (8 - 15 Ton)

Customer: _____ Project: _____
 Ship To: _____ PO Number: _____

 _____ Approved By: _____

Standard Features:

- Welded SB 18ga G90 galvanized steel construction
- 14, 18, 24 or 36 inches high
- Factory installed PT 1x4 wood nailer
- Supplied 1-1/2x1/4" closed cell neoprene gasket
- 1"x1.5# insulation

Options (please check):

- Heavier gauge metal
- 5052-H32 AL or 304 SS construction
- Custom height
- Slope
- Horizontal duct connections
- Turning vane

- 1" or 2" isolation rails
- Seismic rating/stamped
- Filtration
- Metal Building construction
- Other per customer specs

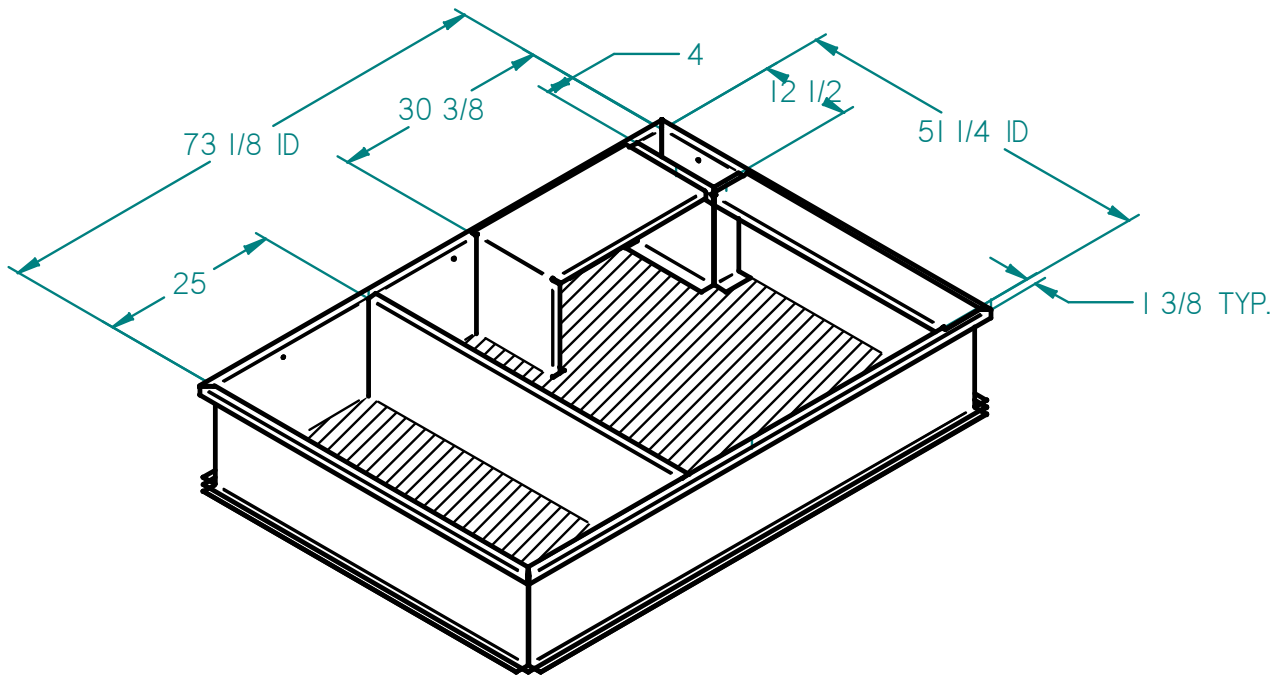

QUANTITY	HEIGHT	OPTIONS	SPECIAL NOTES



1028 Opelika Road,
 Auburn, AL 36830
 Ph: (334) 826-9538
 Fax: (334) 826-9539

AAON

RN-B000-SB-113-14,18,24,36

B Box (8 - 15 Ton) w/ Heat Wheel

Customer: _____ Project: _____
 Ship To: _____ PO Number: _____

 _____ Approved By: _____

Standard Features:

- Welded SB 18ga G90 galvanized steel construction
- 14, 18, 24 or 36 inches high
- Factory installed PT 1x4 wood nailer
- Supplied 1-1/2x1/4" closed cell neoprene gasket
- 1"x1.5# insulation

Options (please check):

- Heavier gauge metal
- 5052-H32 AL or 304 SS construction
- Custom height
- Slope
- Horizontal duct connections
- Turning vane
- 1" or 2" isolation rails
- Seismic rating/stamped
- Filtration
- Metal Building construction
- Other per customer specs

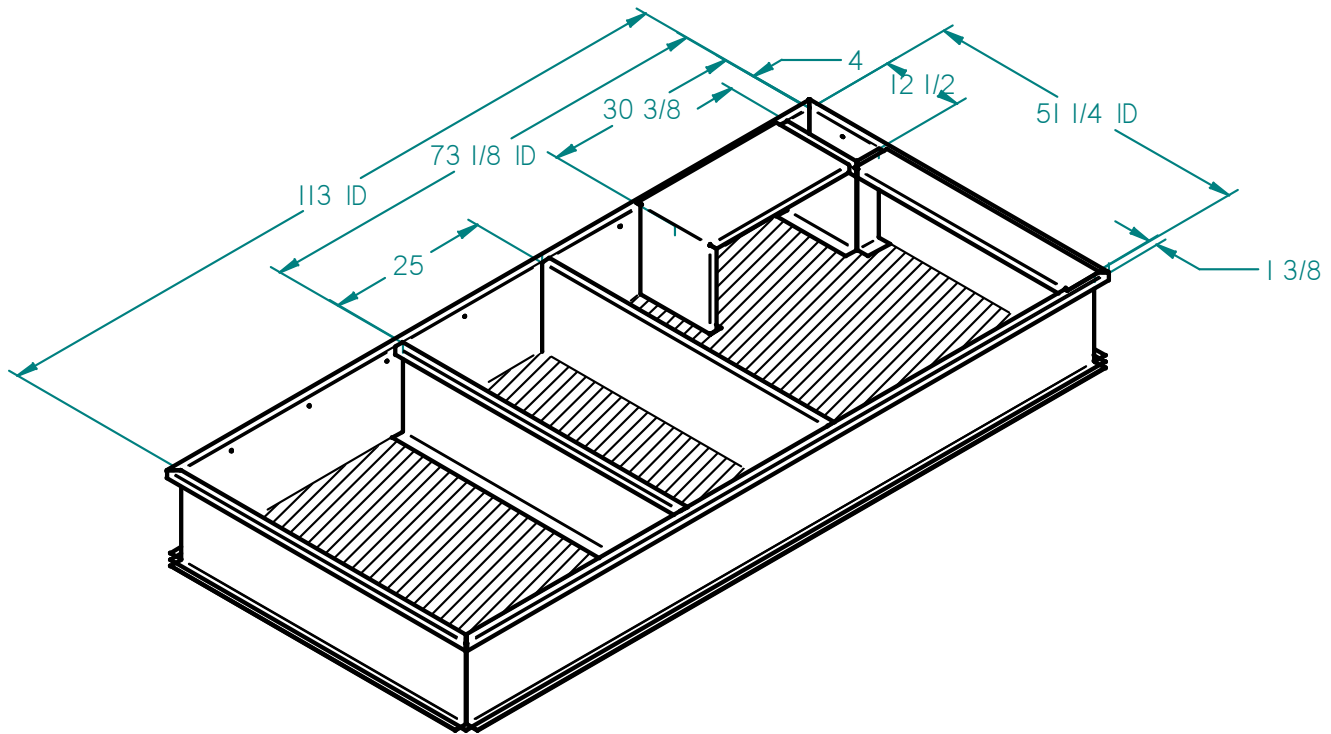

QUANTITY	HEIGHT	OPTIONS	SPECIAL NOTES



1028 Opelika Road,
 Auburn, AL 36830
 Ph: (334) 826-9538
 Fax: (334) 826-9539

AAON

RN-B000-KD/FW-073-14,18,24,36-DR
 B Box (8 - 15 Ton) w/ Duct Rails

Customer: _____ Project: _____
 Ship To: _____ PO Number: _____

 _____ Approved By: _____

Standard Features:

- Knock Down or Welded 18ga G90 galvanized steel construction
- 14, 18, 24 or 36 inches high
- Factory installed PT 1x4 wood nailer
- Supplied 1-1/2x1/4" closed cell neoprene gasket
- 1"x1.5# insulation

Options (please check):

- Heavier gauge metal
- 5052-H32 AL or 304 SS construction
- Custom height
- Slope
- Horizontal duct connections
- Turning vane
- 1" or 2" isolation rails
- Seismic rating/stamped
- Filtration
- Metal Building construction
- Other per customer specs

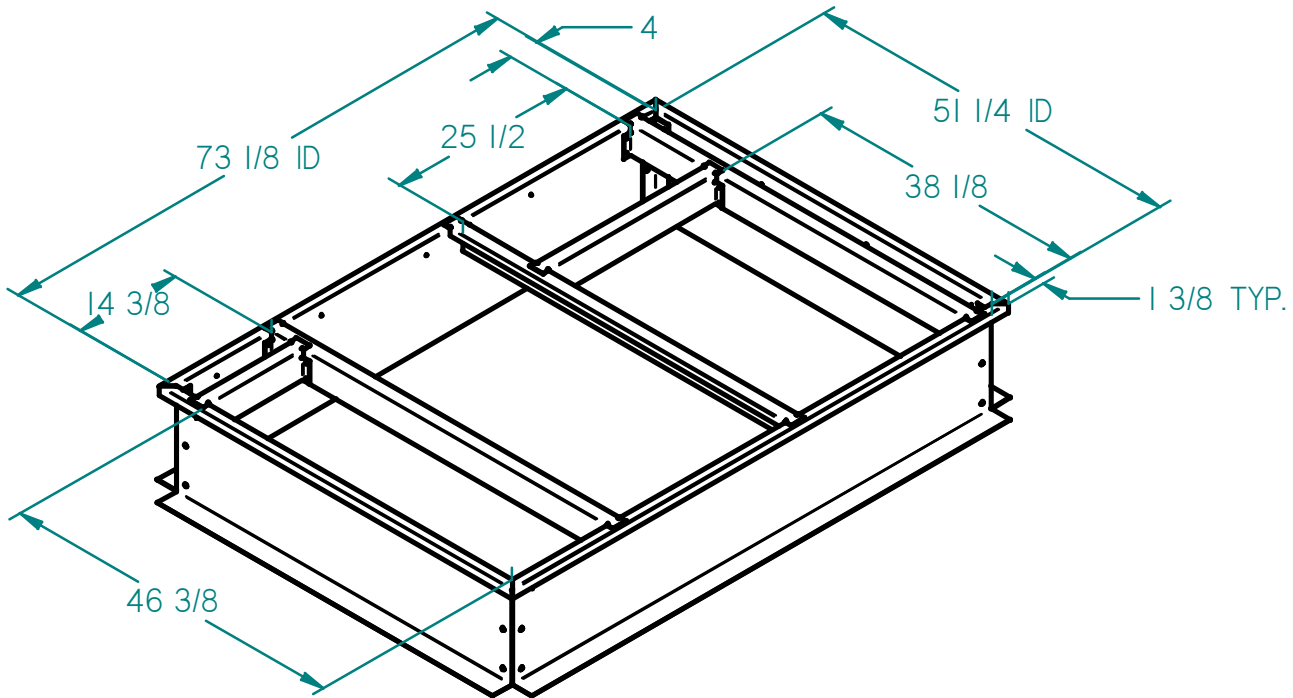

QUANTITY	KD / FW	HEIGHT	OPTIONS	SPECIAL NOTES



1028 Opelika Road,
 Auburn, AL 36830
 Ph: (334) 826-9538
 Fax: (334) 826-9539

AAON

RN-B000-KD/FW-113-14,18,24,36-DR B Box (8 - 15 Ton) w/ Heat Wheel & Duct Rails

Customer: _____ Project: _____
 Ship To: _____ PO Number: _____

 _____ Approved By: _____

Standard Features:

- Knock Down or Welded 18ga G90 galvanized steel construction
- 14, 18, 24 or 36 inches high
- Factory installed PT 1x4 wood nailer
- Supplied 1-1/2x1/4" closed cell neoprene gasket
- 1"x1.5# insulation

Options (please check):

- Heavier gauge metal
- 5052-H32 AL or 304 SS construction
- Custom height
- Slope
- Horizontal duct connections
- Turning vane
- 1" or 2" isolation rails
- Seismic rating/stamped
- Filtration
- Metal Building construction
- Other per customer specs

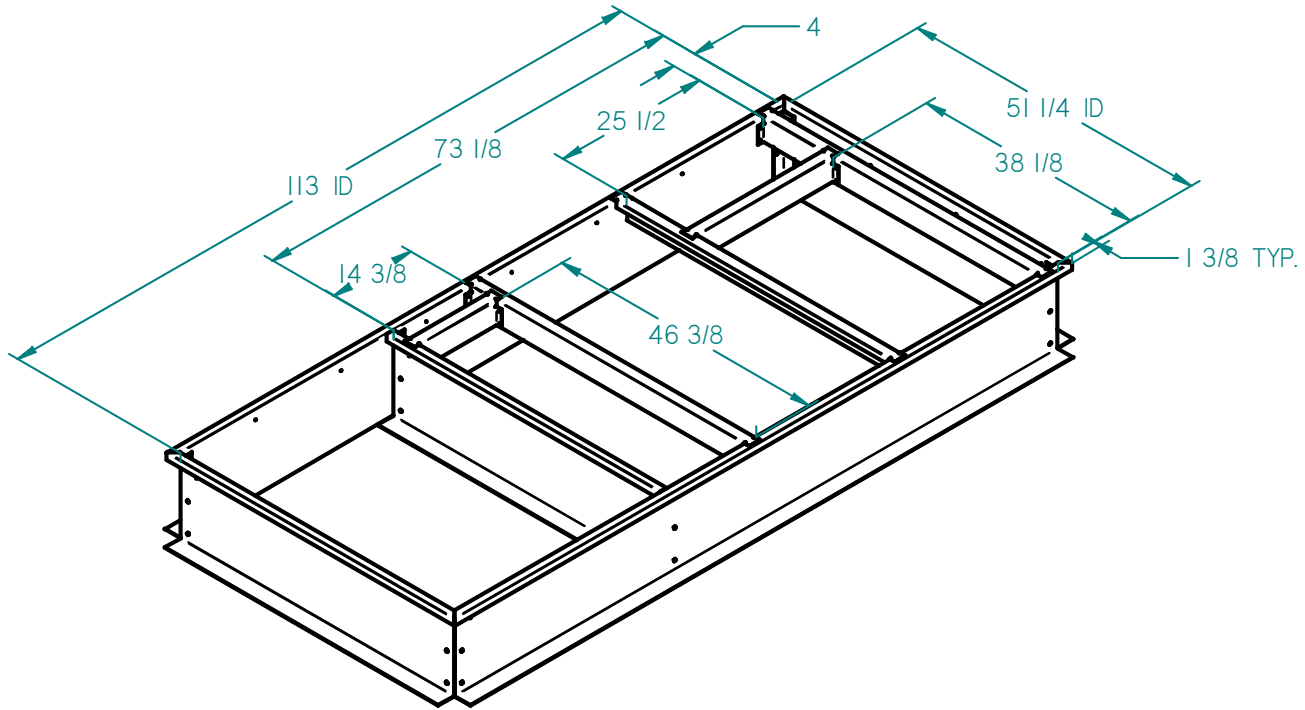

QUANTITY	KD / FW	HEIGHT	OPTIONS	SPECIAL NOTES



1028 Opelika Road,
 Auburn, AL 36830
 Ph: (334) 826-9538
 Fax: (334) 826-9539

AAON

RN-C000-SB-094-14,18,24,36
 C Box (16 - 30 Ton)

Customer: _____ Project: _____
 Ship To: _____ PO Number: _____

 _____ Approved By: _____

Standard Features:

- Welded SB 18ga G90 galvanized steel construction
- 14, 18, 24 or 36 inches high
- Factory installed PT 1x4 wood nailer
- Supplied 1-1/2x1/4" closed cell neoprene gasket
- 1"x1.5# insulation

Options (please check):

- Heavier gauge metal
- 5052-H32 AL or 304 SS construction
- Custom height
- Slope
- Horizontal duct connections
- Turning vane
- 1" or 2" isolation rails
- Seismic rating/stamped
- Filtration
- Metal Building construction
- Other per customer specs

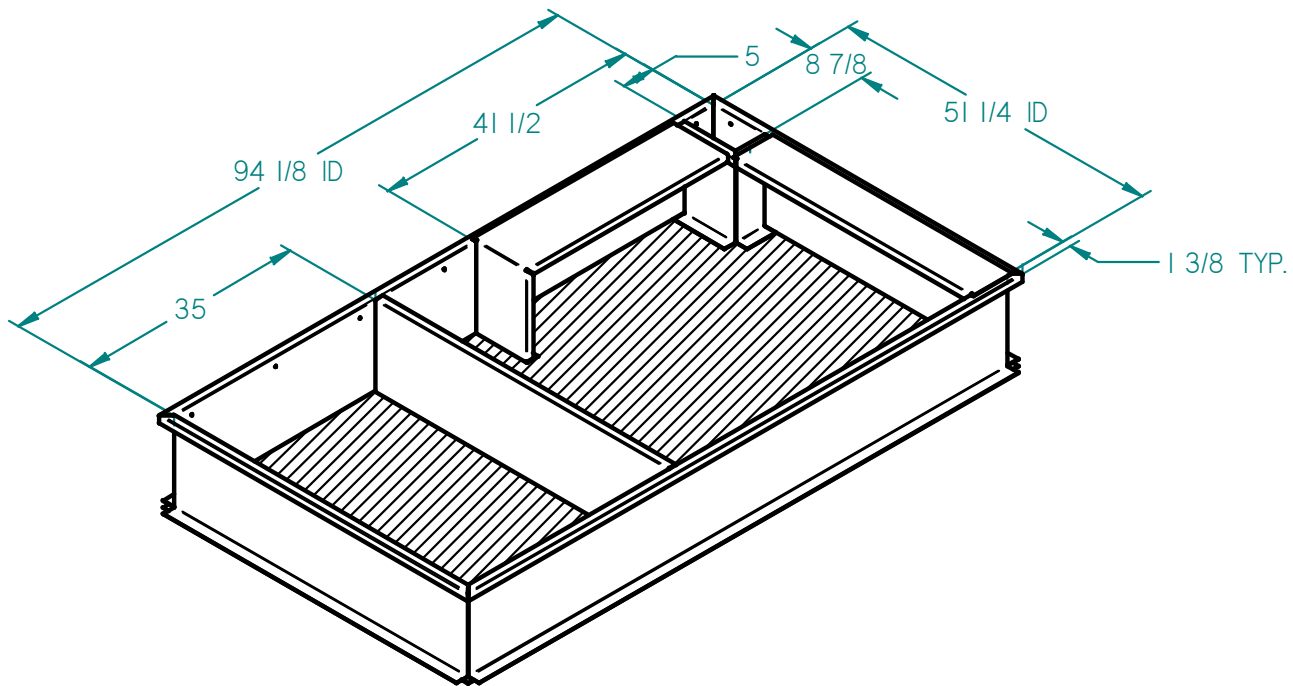

QUANTITY	HEIGHT	OPTIONS	SPECIAL NOTES



1028 Opelika Road,
 Auburn, AL 36830
 Ph: (334) 826-9538
 Fax: (334) 826-9539

AAON

RN-C000-SB-142-14,18,24,36

C Box (16 - 30 Ton) w/ Heat Wheel

Customer: _____ Project: _____
 Ship To: _____ PO Number: _____

 _____ Approved By: _____

Standard Features:

- Welded SB 18ga G90 galvanized steel construction
- 14, 18, 24 or 36 inches high
- Factory installed PT 1x4 wood nailer
- Supplied 1-1/2x1/4" closed cell neoprene gasket
- 1"x1.5# insulation

Options (please check):

- Heavier gauge metal
- 5052-H32 AL or 304 SS construction
- Custom height
- Slope
- Horizontal duct connections
- Turning vane

- 1" or 2" isolation rails
- Seismic rating/stamped
- Filtration
- Metal Building construction
- Other per customer specs

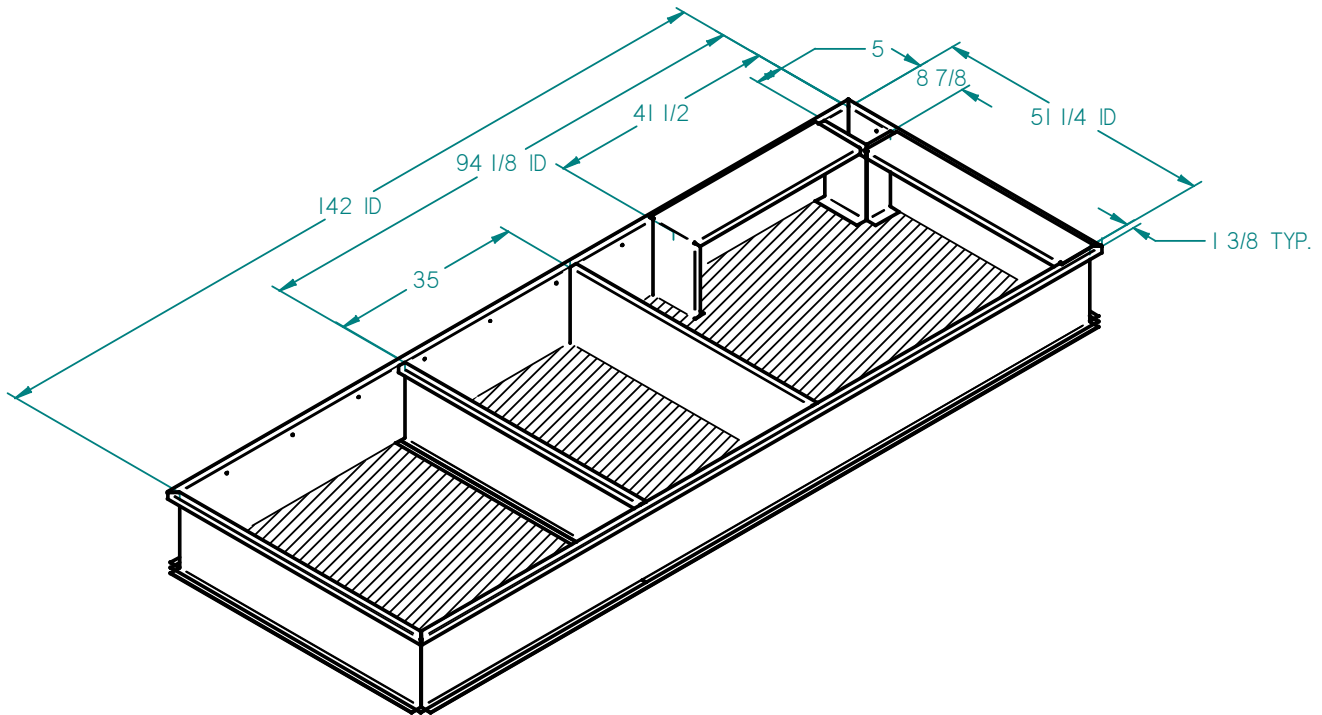

QUANTITY	HEIGHT	OPTIONS	SPECIAL NOTES



1028 Opelika Road,
 Auburn, AL 36830
 Ph: (334) 826-9538
 Fax: (334) 826-9539

AAON

RN-C000-KD/FW-094-14,18,24,36-DR C Box (16 - 30 Ton) w/ Duct Rails

Customer: _____ Project: _____
 Ship To: _____ PO Number: _____

 _____ Approved By: _____

Standard Features:

- Knock Down or Welded 18ga or 14ga G90 galvanized steel construction
- 14, 18, 24 or 36 inches high
- Factory installed PT 1x4 wood nailer
- Supplied 1-1/2x1/4" closed cell neoprene gasket
- 1"x1.5# insulation

Options (please check):

- Heavier gauge metal
- 5052-H32 AL or 304 SS construction
- Custom height
- Slope
- Horizontal duct connections
- Turning vane
- 1" or 2" isolation rails
- Seismic rating/stamped
- Filtration
- Metal Building construction
- Other per customer specs

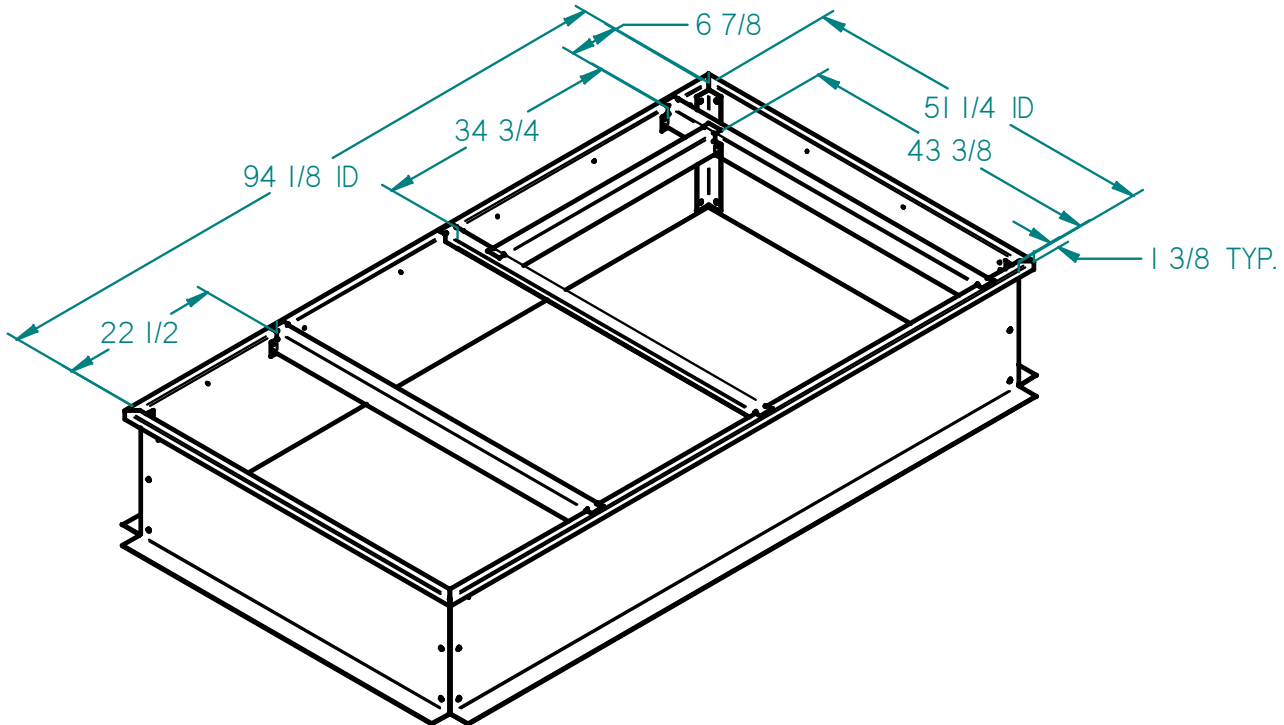

QUANTITY	KD / FW	HEIGHT	OPTIONS	SPECIAL NOTES



1028 Opelika Road,
 Auburn, AL 36830
 Ph: (334) 826-9538
 Fax: (334) 826-9539

AAON

RN-C000-KD/FW-142-14,18,24,36-DR

C Box (16 - 30 Ton) w/ Heat Wheel & Duct Rails

Customer: _____ Project: _____
 Ship To: _____ PO Number: _____

 _____ Approved By: _____

Standard Features:

- Knock Down or Welded 18ga or 14ga G90 galvanized steel construction
- 14, 18, 24 or 36 inches high
- Factory installed PT 1x4 wood nailer
- Supplied 1-1/2x1/4" closed cell neoprene gasket
- 1"x1.5# insulation

Options (please check):

- Heavier gauge metal
- 5052-H32 AL or 304 SS construction
- Custom height
- Slope
- Horizontal duct connections
- Turning vane
- 1" or 2" isolation rails
- Seismic rating/stamped
- Filtration
- Metal Building construction
- Other per customer specs

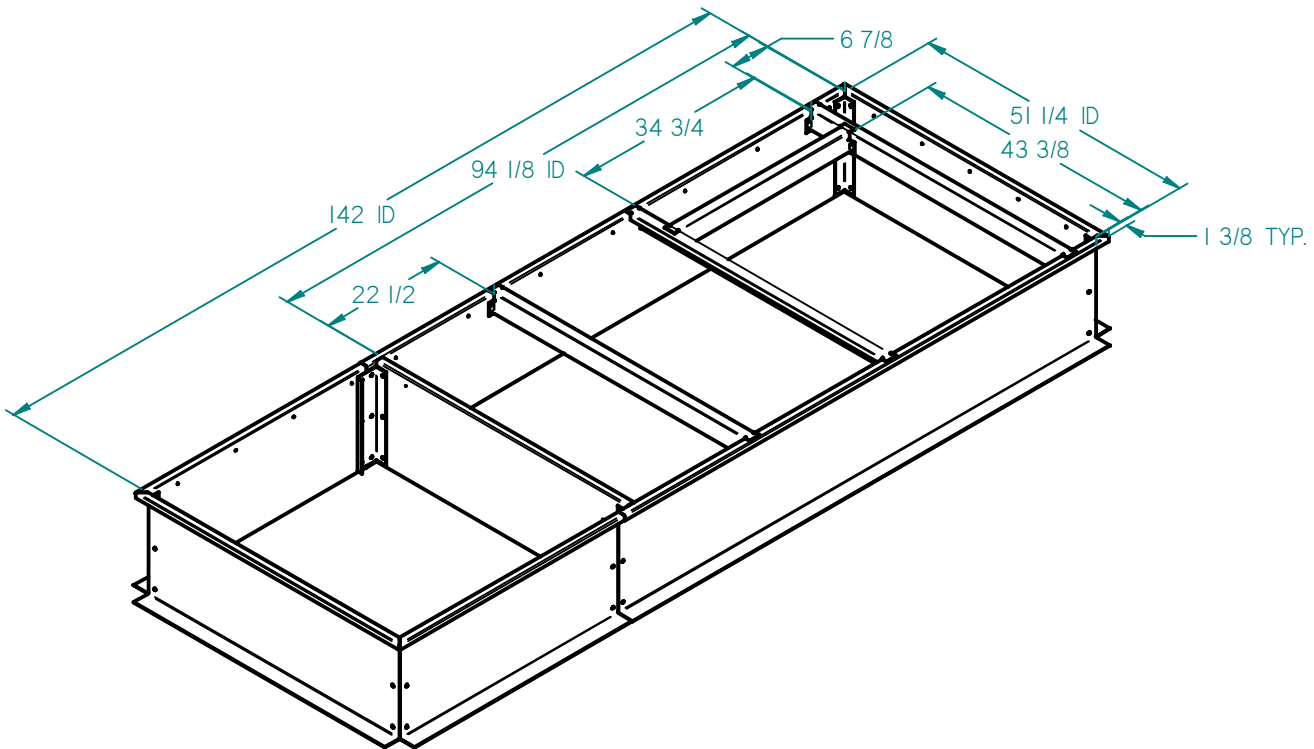

QUANTITY	KD / FW	HEIGHT	OPTIONS	SPECIAL NOTES



1028 Opelika Road,
 Auburn, AL 36830
 Ph: (334) 826-9538
 Fax: (334) 826-9539

AAON

RN-D000-SB-146-14,18,24,36
 D Box (26 - 70 Ton)

Customer: _____ Project: _____
 Ship To: _____ PO Number: _____

 _____ Approved By: _____

Standard Features:

- Welded SB 14ga G90 galvanized steel construction
- 14, 18, 24 or 36 inches high
- Factory installed PT 1x4 wood nailer
- Supplied 1-1/2x1/4" closed cell neoprene gasket
- 1"x1.5# insulation

Options (please check):

- Heavier gauge metal
- 5052-H32 AL or 304 SS construction
- Custom height
- Slope
- Horizontal duct connections
- Turning vane
- 1" or 2" isolation rails
- Seismic rating/stamped
- Filtration
- Metal Building construction
- Other per customer specs

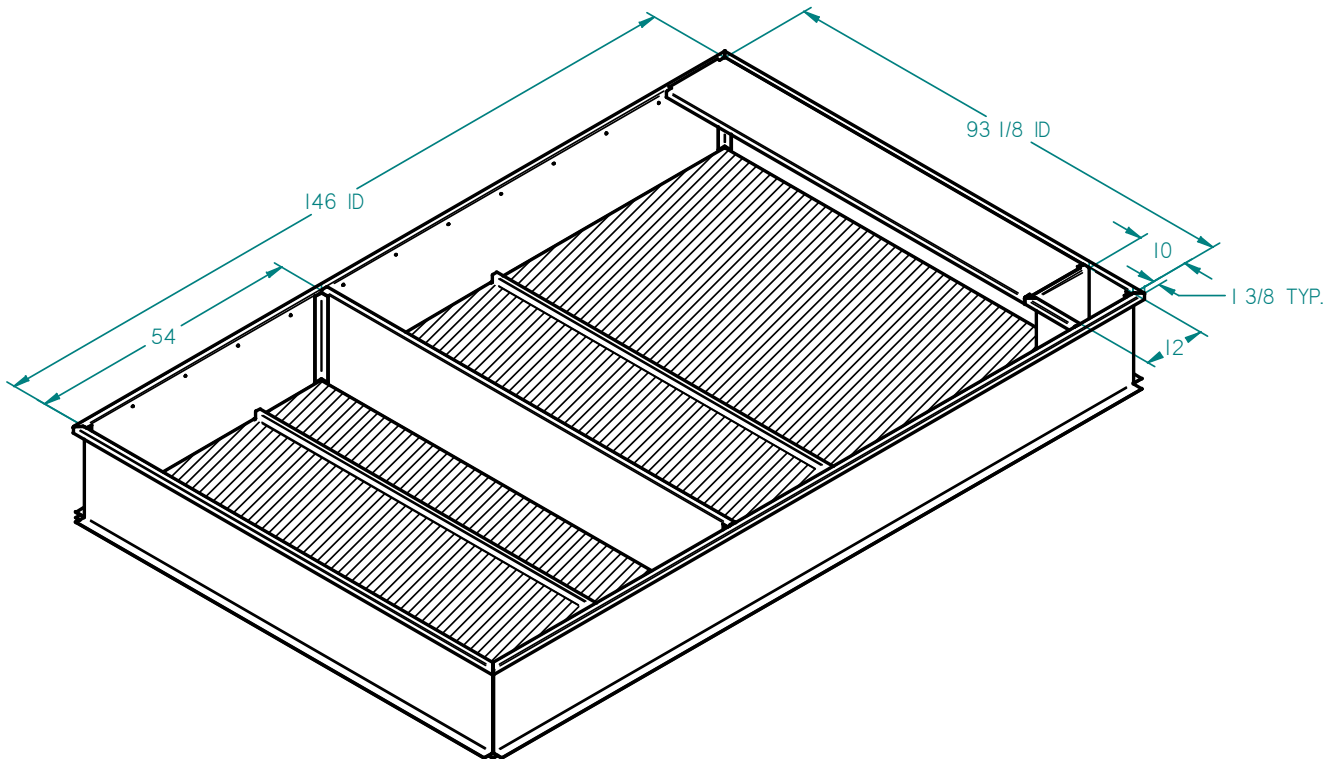

QUANTITY	HEIGHT	OPTIONS	SPECIAL NOTES



1028 Opelika Road,
 Auburn, AL 36830
 Ph: (334) 826-9538
 Fax: (334) 826-9539

AAON

RN-D000-SB-193-14,18,24,36 D Box (26 - 70 Ton) w/ Heat Wheel

Customer: _____ Project: _____
 Ship To: _____ PO Number: _____

 _____ Approved By: _____

Standard Features:

- Welded SB 14ga G90 galvanized steel construction
- 14, 18, 24 or 36 inches high
- Factory installed PT 1x4 wood nailer
- Supplied 1-1/2x1/4" closed cell neoprene gasket
- 1"x1.5# insulation

Options (please check):

- Heavier gauge metal
- 5052-H32 AL or 304 SS construction
- Custom height
- Slope
- Horizontal duct connections
- Turning vane

- 1" or 2" isolation rails
- Seismic rating/stamped
- Filtration
- Metal Building construction
- Other per customer specs

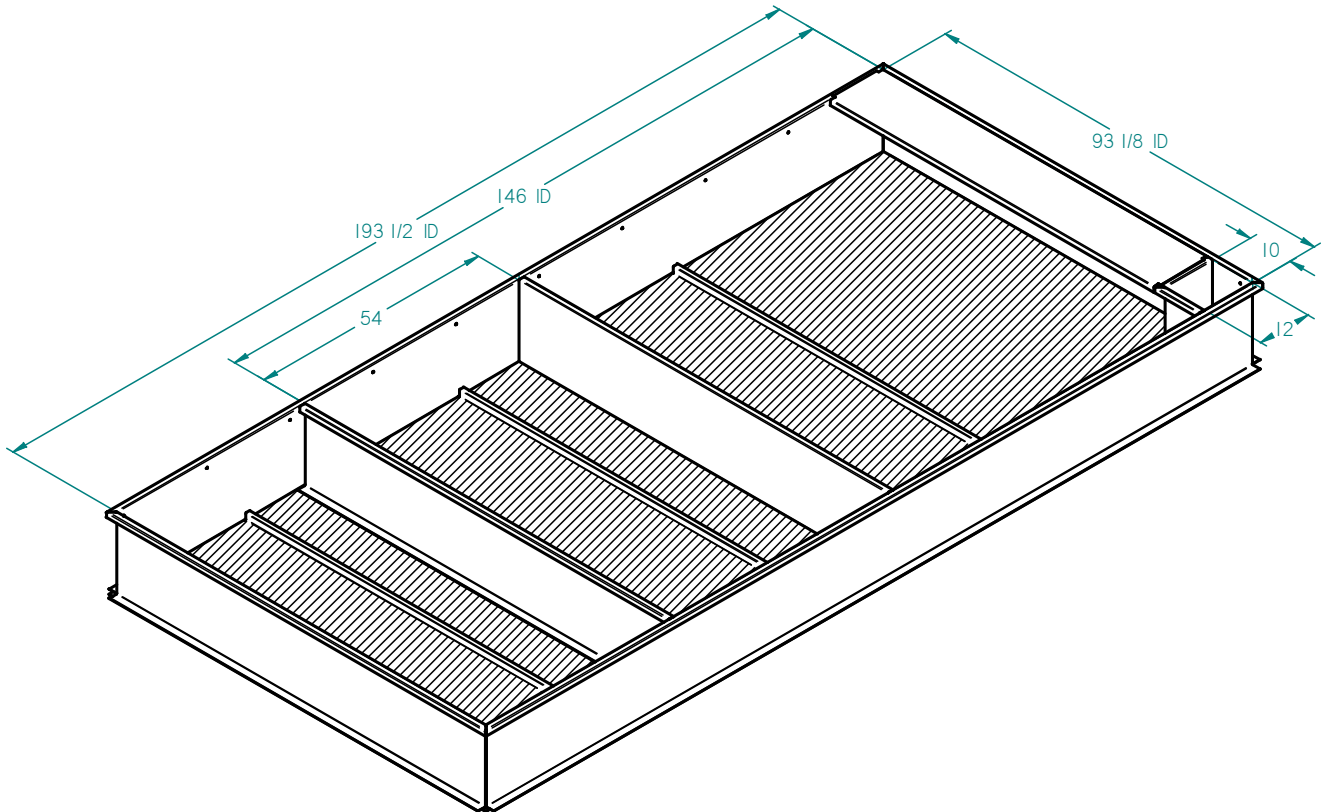

QUANTITY	HEIGHT	OPTIONS	SPECIAL NOTES



1028 Opelika Road,
Auburn, AL 36830
Ph: (334) 826-9538
Fax: (334) 826-9539

AAON

RN-D000-KD/FW-146-14,18,24,36-DR D Box (26 - 70 Ton) w/ Duct Rails

Customer: _____ Project: _____
 Ship To: _____ PO Number: _____

 _____ Approved By: _____

Standard Features:

- Knock Down or Welded 14ga G90 galvanized steel construction
- 14, 18, 24 or 36 inches high
- Factory installed PT 1x4 wood nailer
- Supplied 1-1/2x1/4" closed cell neoprene gasket
- 1"x1.5# insulation

Options (please check):

- Heavier gauge metal
- 5052-H32 AL or 304 SS construction
- Custom height
- Slope
- Horizontal duct connections
- Turning vane
- 1" or 2" isolation rails
- Seismic rating/stamped
- Filtration
- Metal Building construction
- Other per customer specs

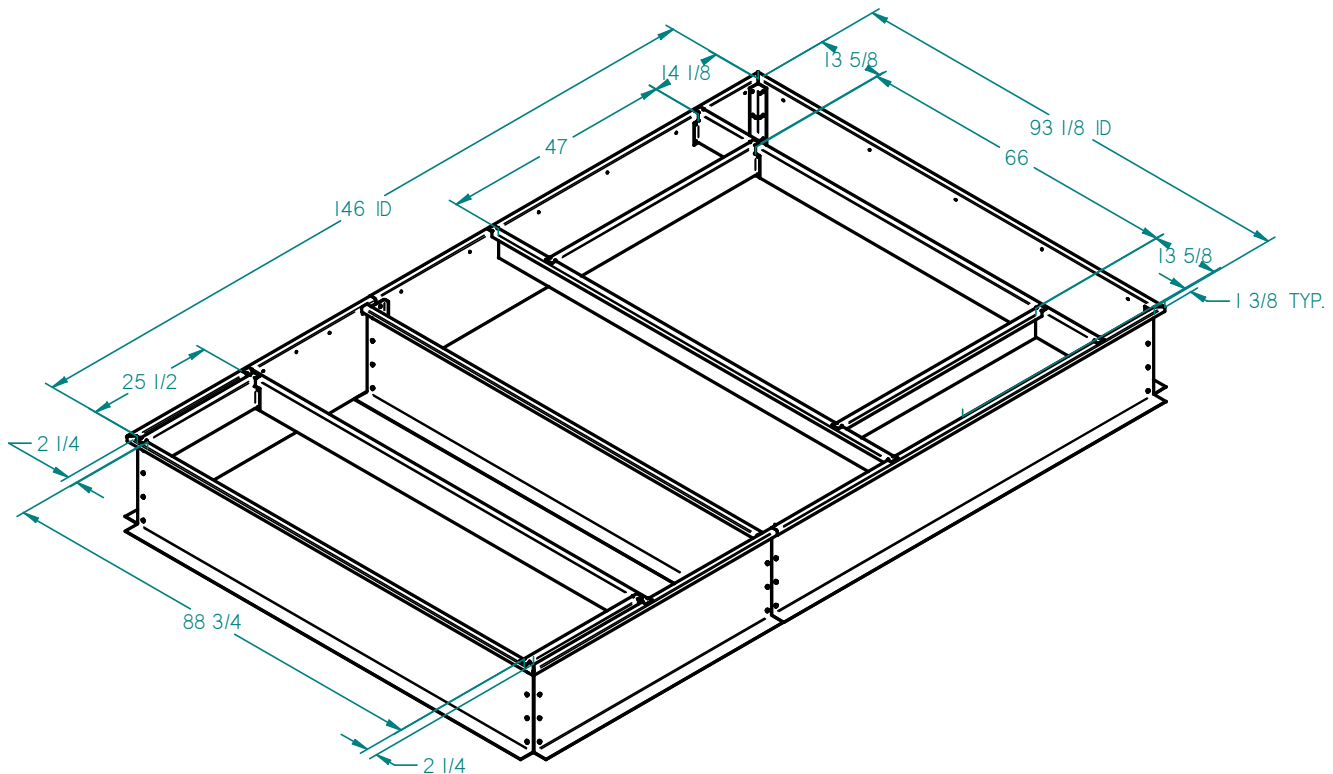

QUANTITY	KD / FW	HEIGHT	OPTIONS	SPECIAL NOTES



1028 Opelika Road,
 Auburn, AL 36830
 Ph: (334) 826-9538
 Fax: (334) 826-9539

AAON

RN-D000-KD/FW-193-14,18,24,36-DR

D Box (26 - 70 Ton) w/ Heat Wheel & Duct Rails

Customer: _____ Project: _____
 Ship To: _____ PO Number: _____

 _____ Approved By: _____

Standard Features:

- Knock Down or Welded 14ga G90 galvanized steel construction
- 14, 18, 24 or 36 inches high
- Factory installed PT 1x4 wood nailer
- Supplied 1-1/2x1/4" closed cell neoprene gasket
- 1"x1.5# insulation

Options (please check):

- Heavier gauge metal
- 5052-H32 AL or 304 SS construction
- Custom height
- Slope
- Horizontal duct connections
- Turning vane

- 1" or 2" isolation rails
- Seismic rating/stamped
- Filtration
- Metal Building construction
- Other per customer specs

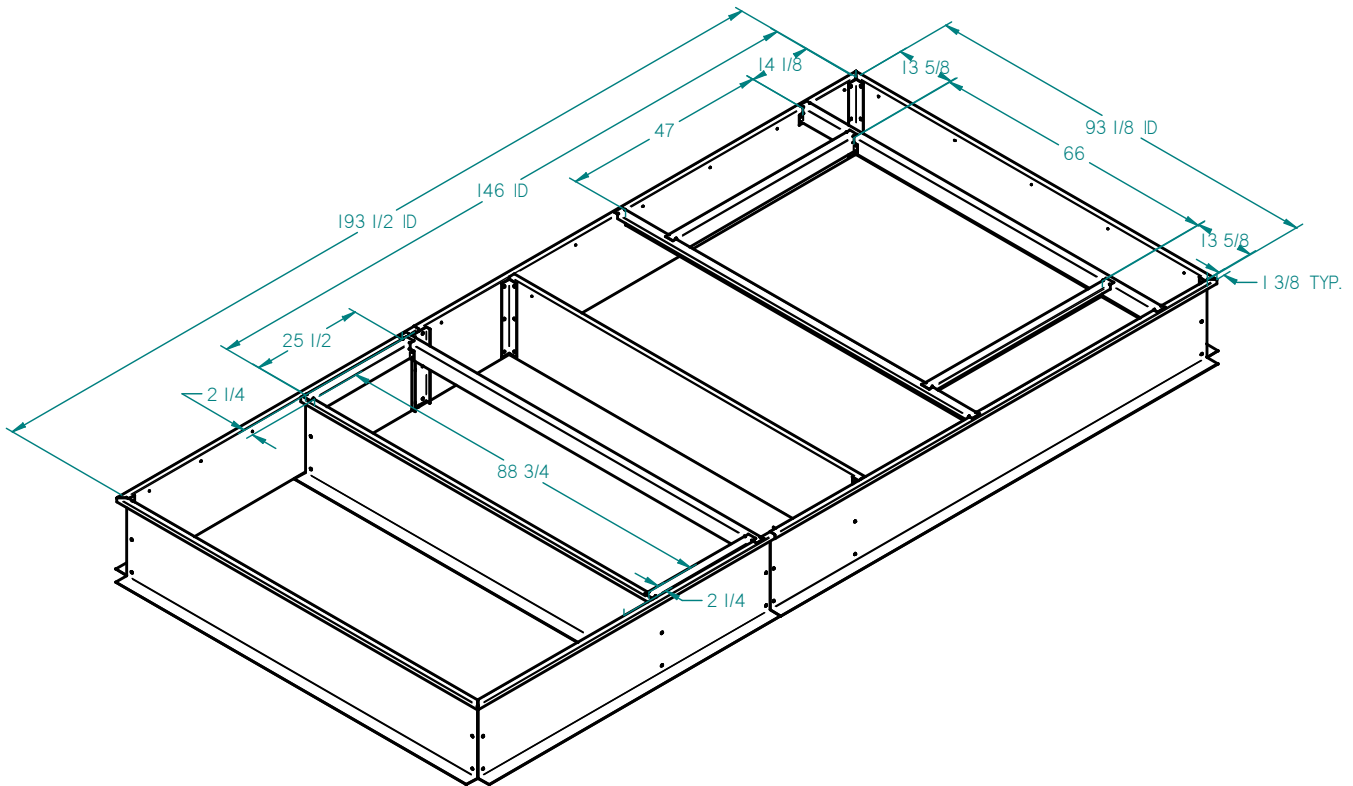

QUANTITY	KD / FW	HEIGHT	OPTIONS	SPECIAL NOTES



1028 Opelika Road,
 Auburn, AL 36830
 Ph: (334) 826-9538
 Fax: (334) 826-9539

AAON

RN-D000-KD/FW-193-14,18,24,36-DR

D Box (26 - 70 Ton) w/ Power Return & Duct Rails

Customer: _____ Project: _____
 Ship To: _____ PO Number: _____

 _____ Approved By: _____

Standard Features:

- Knock Down or Welded 14ga G90 galvanized steel construction
- 14, 18, 24 or 36 inches high
- Factory installed PT 1x4 wood nailer
- Supplied 1-1/2x1/4" closed cell neoprene gasket
- 1"x1.5# insulation

Options (please check):

- Heavier gauge metal
- 5052-H32 AL or 304 SS construction
- Custom height
- Slope
- Horizontal duct connections
- Turning vane

- 1" or 2" isolation rails
- Seismic rating/stamped
- Filtration
- Metal Building construction
- Other per customer specs

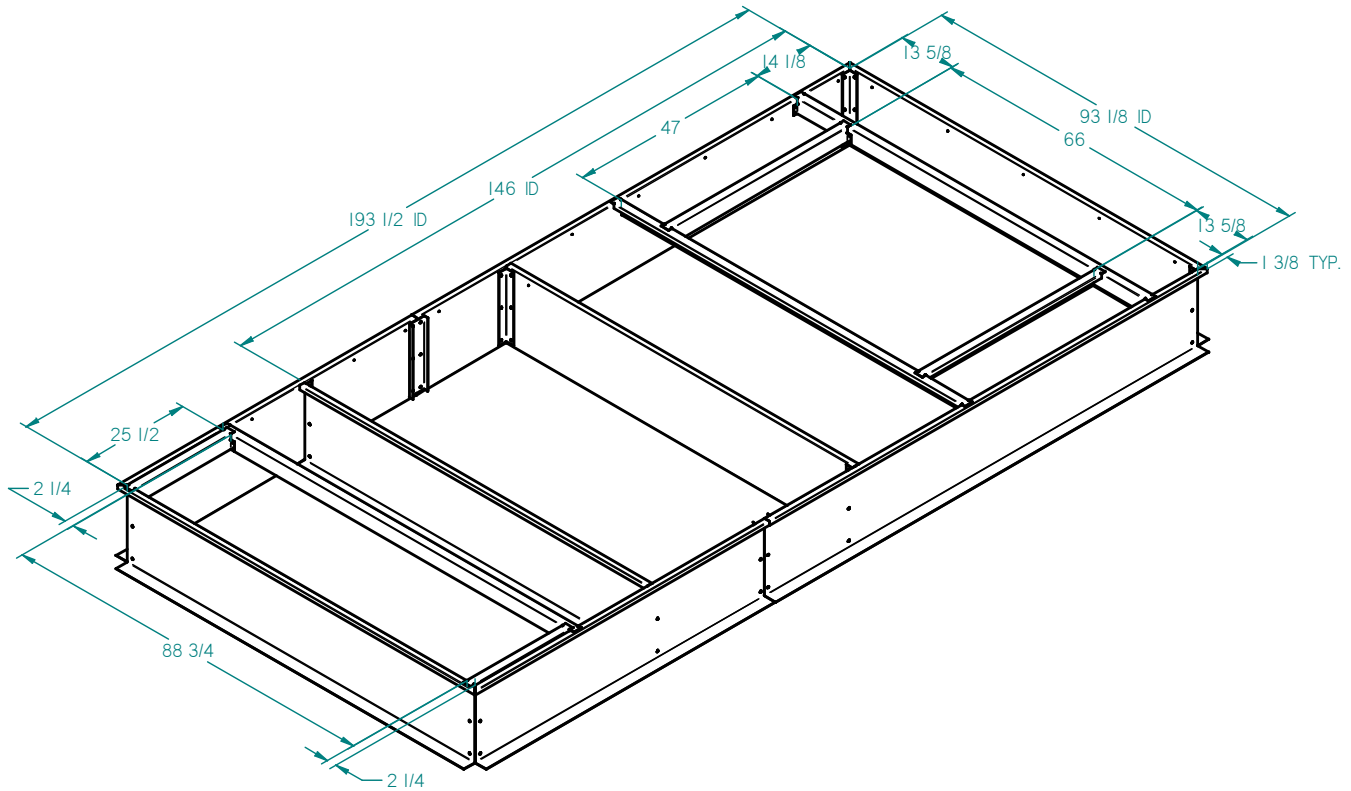

QUANTITY	KD / FW	HEIGHT	OPTIONS	SPECIAL NOTES

