



1028 Opelika Road,  
 Auburn, AL 36830  
 Ph: (334) 826-9538  
 Fax: (334) 826-9539

# AAON

HB-KD,FW-42-14,18,24  
 (2 - 5 Ton)

Customer: \_\_\_\_\_ Project: \_\_\_\_\_  
 Ship To: \_\_\_\_\_ PO Number: \_\_\_\_\_  
 \_\_\_\_\_ Approved By: \_\_\_\_\_

**Standard Features:**

- Knockdown or welded 18ga G90 galvanized steel construction
- 14, 18 or 24 inches high
- Factory installed PT 1x4 wood nailer
- Supplied 1-1/2x1/4" closed cell neoprene gasket
- 1"x1.5# insulation

**Options (please check):**

- Heavier gauge metal
- 5052-H32 AL or 304 SS construction
- Custom height
- Slope
- Horizontal duct connections
- Turning vane
- 1" or 2" isolation rails
- Seismic rating/stamped
- Filtration
- Metal Building construction
- Other per customer specs

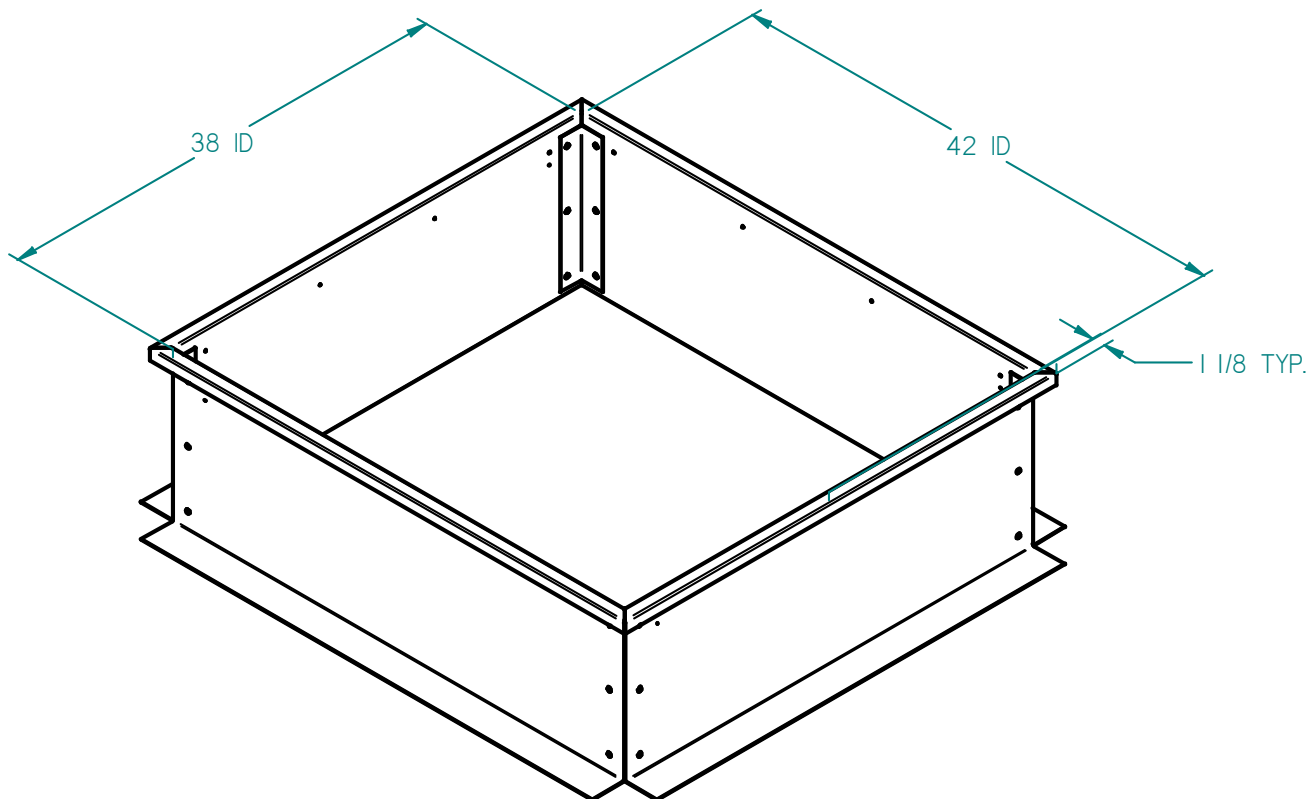

QUANTITY	KD or FW	HEIGHT	OPTIONS	SPECIAL NOTES