



# CARRIER

48/50 HG 014-028

48/50 HJ 020-028

1028 Opelika Road,  
 Auburn, AL 36830  
 Ph: (334) 826-9538  
 Fax: (334) 826-9539

Customer: \_\_\_\_\_ Project: \_\_\_\_\_

Ship To: \_\_\_\_\_  
 \_\_\_\_\_  
 \_\_\_\_\_

**Standard Features:**

- Knock Down or Fully Welded 14ga G90 galvanized steel construction
- 14 inches high
- Factory installed PT 2x4 wood nailer
- Supplied 1-1/2x1/4" closed cell neoprene gasket

**Options (please check):**

- Heavier gauge metal
- 5052-H32 AL or 304 SS construction
- Custom height
- Horizontal duct connections\*
- Turning vane\*
- 1" or 2" isolation rails

- Seismic rating/stamped
- Filtration\*
- Metal Building construction
- Other per customer specs

\* Welded curb only

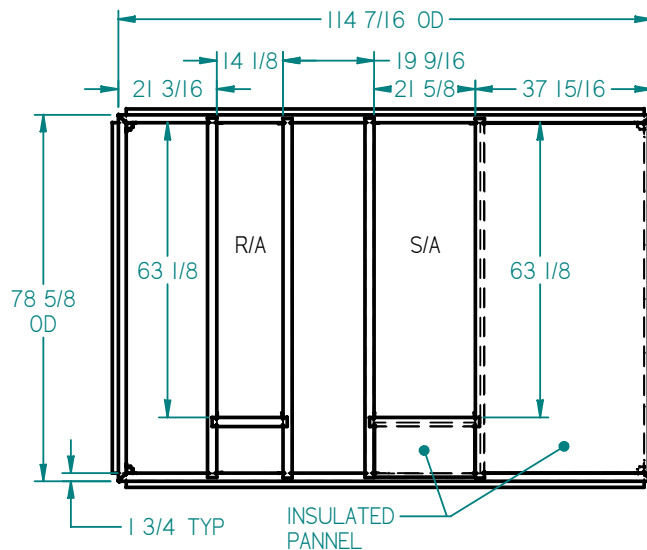

QUANTITY	KD / FW	HEIGHT	OPTIONS	SPECIAL NOTES